

SOCKS PACKAGING

FASTENING DEVICE TO APPLY CARDBOARD RIDERS AND TAGS ON
TEXTILE PRODUCT

REVOLVING FASTENER

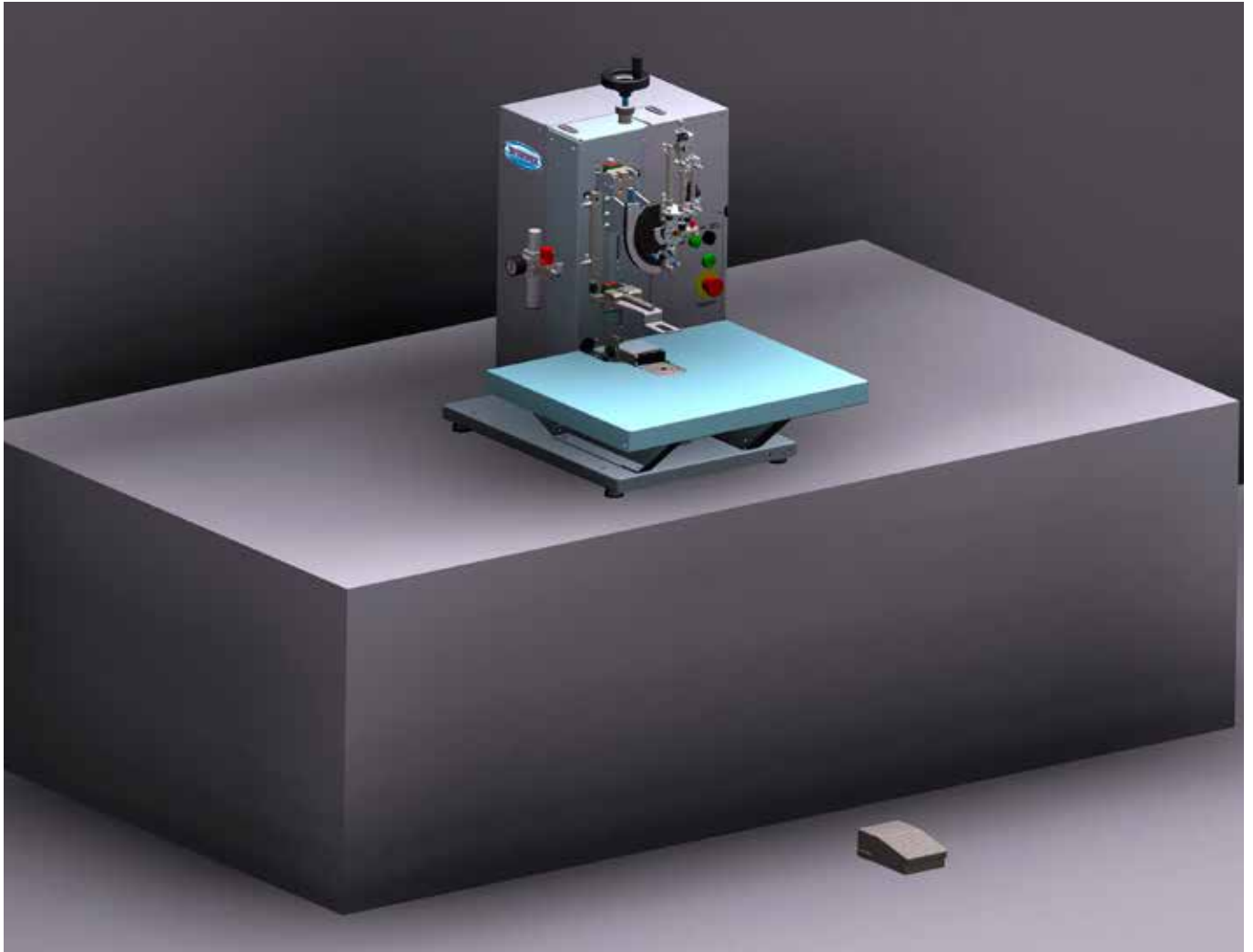

SOCKS BOARDING REVOLVING FASTENER

The new device patented by Tecnopea is equipped with a revolving automatic loader for the fastener cartridges, to guarantee a longer autonomy of operation required on the automatic packaging lines.

Equipped with a thin needle it minimizes the possibility of damaging the fibers especially in light products.

The new filament feeding system allows the use of cartridges from different manufacturers.

SOCKS BOARDING REVOLVING FASTENER

Specifications	Values
Dimensions	770 x 610 x 870 (h)
Air pressure	6 bar
Air consumption	2,5 m ³
Installed power	0,6 kW
Diametro ago needle diameter	1,6 mm
Fastener length	6 - 70 mm

Features
High productivity
Revolving magazine to load 8 cartridges with 100 filaments each
Filaments depletion control system
Cartridges depletion control system
Alarms due to malfunction
Possibility to use fasteners from different manufacturers



Fastener con alimentatore automatico



Fastener con alimentazione manuale

SOCKS BOARDING REVOLVING FASTENER

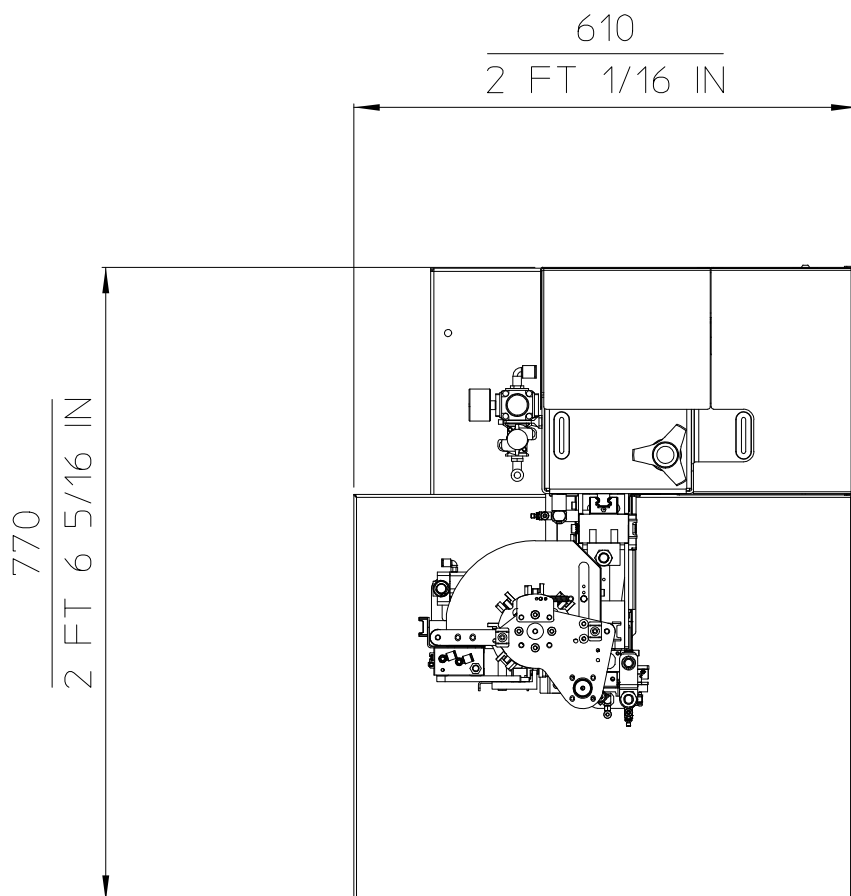
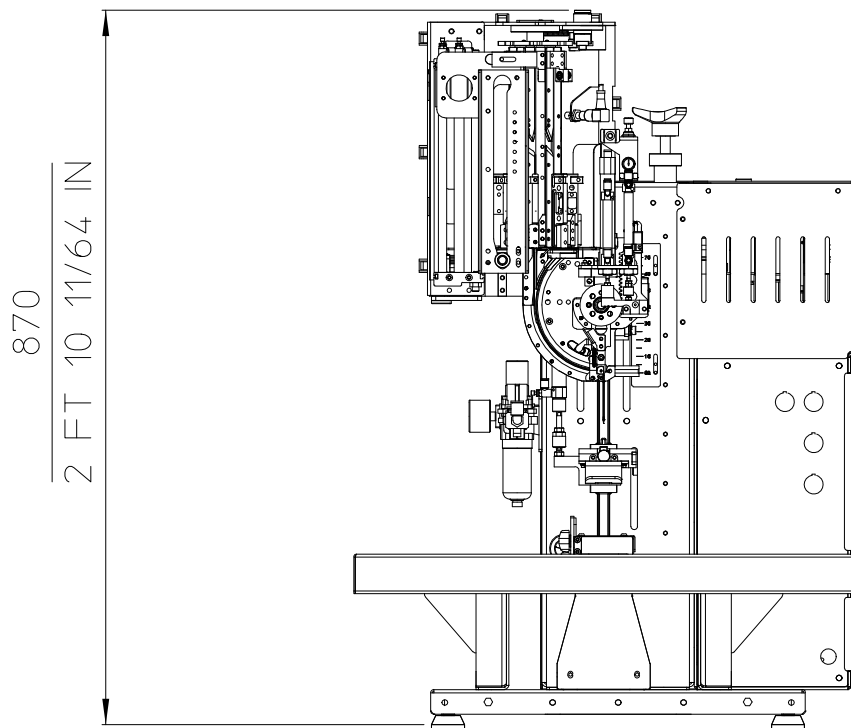

TECNOPEA



TECNOPEA S.R.L.

Via Don Eridano Torri, 2

25027 Quinzano d'Oglio, Brescia - Italy

Tel.: +39 030 992 3780 - Fax: +39 030 9923996

info@tecnopea.com - www.tecnopea.com